

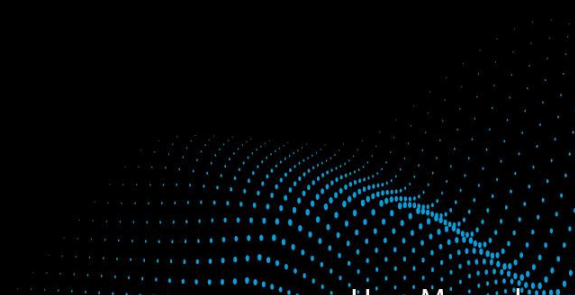

# DeskMini

Beyond the Edge

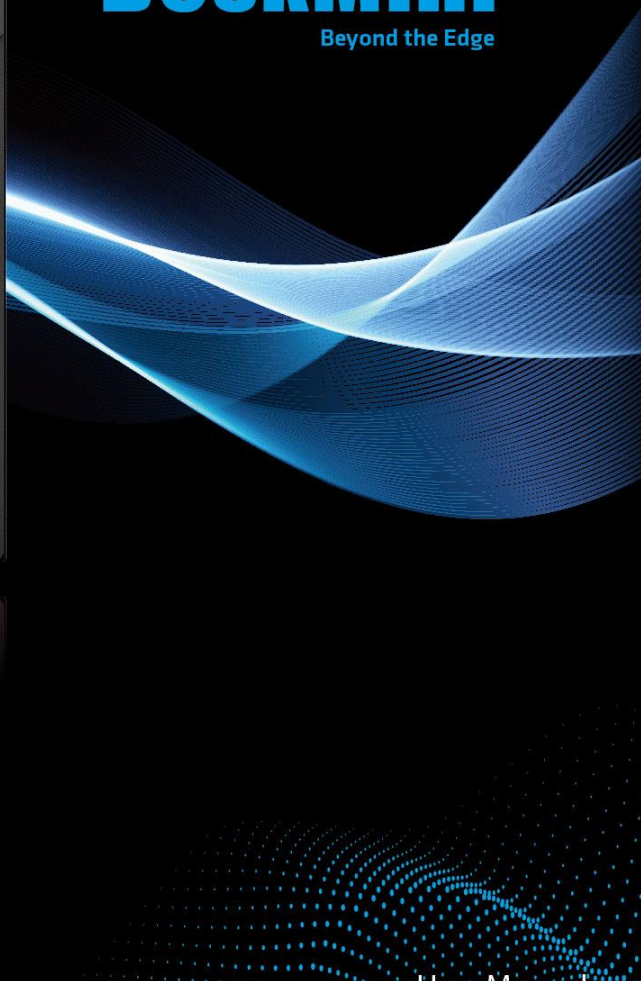

Version 1.0

Published June 2020



This device complies with Part 15 of the FCC Rules. Operation is subject to the following two conditions:

- (1) this device may not cause harmful interference, and
- (2) this device must accept any interference received, including interference that may cause undesired operation.

### CALIFORNIA, USA ONLY

The Lithium battery adopted on this motherboard contains Perchlorate, a toxic substance controlled in Perchlorate Best Management Practices (BMP) regulations passed by the California Legislature. When you discard the Lithium battery in California, USA, please follow the related regulations in advance.

“Perchlorate Material-special handling may apply, see [www.dtsc.ca.gov/hazardouswaste/perchlorate](http://www.dtsc.ca.gov/hazardouswaste/perchlorate)”

## AUSTRALIA ONLY

Our goods come with guarantees that cannot be excluded under the Australian Consumer Law. You are entitled to a replacement or refund for a major failure and compensation for any other reasonably foreseeable loss or damage caused by our goods. You are also entitled to have the goods repaired or replaced if the goods fail to be of acceptable quality and the failure does not amount to a major failure.

The terms HDMI™ and HDMI High-Definition Multimedia Interface, and the HDMI logo are trademarks or registered trademarks of HDMI Licensing LLC in the United States and other countries.



# Contents

<b>Chapter 1 Introduction</b>	<b>1</b>
1.1 Package Contents	1
1.2 Specifications	2
<b>Chapter 2 Product Overview</b>	<b>4</b>
2.1 Front View	4
2.2 Rear View	5
1.3 Motherboard Layout	6
<b>Chapter 3 Hardware Installation</b>	<b>13</b>
3.1 Begin Installation	13
3.2 Installing the CPU	14
3.3 Installing the CPU Fan and Heatsink	16
3.4 Installing Memory Modules (SO-DIMM)	17
3.5 Installing the WiFi Module	18
3.6 Installing the M.2 SSD (Type 2280)	19
3.7 Installing the 2.5-inch HDD/SSD	20
3.8 Complete	22
3.9 Installing the VESA Bracket (Optional)	23
3.10 Installing the WiFi Antennas (Optional)	25
<b>Chapter 4 Software and Utilities Operation</b>	<b>27</b>
4.1 Installing Drivers	27



<b>Chapter 5 UEFI SETUP UTILITY</b>	<b>28</b>
5.1 Introduction	28
5.2 EZ Mode	29
5.3 Advanced Mode	30
5.3.1 UEFI Menu Bar	30
5.3.2 Navigation Keys	31
5.4 Main Screen	32
5.5 OC Tweaker Screen	33
5.6 Advanced Screen	41
5.6.1 CPU Configuration	42
5.6.2 Chipset Configuration	44
5.6.3 Storage Configuration	47
5.6.4 ACPI Configuration	48
5.6.5 USB Configuration	49
5.6.6 Trusted Computing	50
5.7 Tools	52
5.8 Hardware Health Event Monitoring Screen	54
5.9 Security Screen	55
5.10 Boot Screen	56

# Chapter 1 Introduction

Thank you for purchasing DeskMini H470 series barebone system. In this documentation, Chapter 1 and 2 contains the introduction of the barebone system and step-by-step installation guides. Chapter 3 contains the guide of hardware installation. Chapter 4 contains the operation guide of the software and utilities. Chapter 5 contains the configuration guide of the BIOS setup.



*Because the barebone system specifications and the BIOS software might be updated, the content of this documentation will be subject to change without notice.*

## 1.1 Package Contents

- DeskMini H470 series Barebone System with:  
DeskMini H470 series Chassis  
Motherboard (pre-installed)  
\*The barebone system does not include memory, hard drive, WiFi module and M.2 SSD.
- 120W/19V Power Adapter & Power Cord (Optional)
- SATA Cable (Optional)
- Screws Package (HDD Screw x 6, M.2 Screw x 3pcs, Rubber Foot x 4pcs)
- Support CD (Optional)
- Quick Installation Guide (Optional)

\*Package contents may vary based on local distribution.



*If any items are missing or appear damaged, contact your authorized dealer.*

## 1.2 Specifications

<b>System Model</b>	<ul style="list-style-type: none"><li>• DeskMini H470</li></ul>
<b>Chassis</b>	<ul style="list-style-type: none"><li>• 1.92L (155 x 155 x 80mm)</li></ul>
<b>CPU</b>	<ul style="list-style-type: none"><li>• Supports 10<sup>th</sup> Gen Intel® Core™ Processors (Socket 1200)</li></ul>
<b>CPU cooling</b>	<ul style="list-style-type: none"><li>• Supports Standard Intel Box Fan Coolers</li></ul>
<b>Motherboard</b>	<ul style="list-style-type: none"><li>• H470M-STX</li></ul>
<b>Chipset</b>	<ul style="list-style-type: none"><li>• Intel® H470</li></ul>
<b>Graphics</b>	<ul style="list-style-type: none"><li>• Intel® UHD Graphics</li></ul>
<b>Memory</b>	<ul style="list-style-type: none"><li>• Supports DDR4 2933MHz, 2 x SO-DIMM Slots, Max. 64GB</li></ul>
<b>Audio</b>	<ul style="list-style-type: none"><li>• Realtek ALC233 Audio Codec</li></ul>
<b>LAN</b>	<ul style="list-style-type: none"><li>• Intel Gigabit I219V LAN</li></ul>
<b>Expansion Slot</b>	<ul style="list-style-type: none"><li>• 1 x M.2 Socket (Key E), supports type 2230 WiFi/BT module and Intel® CNVi (Integrated WiFi/BT)</li></ul>
<b>Front I/O</b>	<ul style="list-style-type: none"><li>• Power Button (with power LED &amp; HDD LED)</li><li>• 1 x USB 3.2 Gen2 (Type-A), 1 x USB 3.2 Gen1 (Type-C), 1 x Headphone/Headset Jack , 1 x MIC-In</li></ul>
<b>Rear I/O</b>	<ul style="list-style-type: none"><li>• 1 x VGA , 1 x HDMI, 1 x DP, 4 x USB 3.2 Gen1 Type-A, 1 x USB 3.2 Gen1 Type-C , 1 x LAN, 1 x DC-In Jack</li></ul>

**Storage**

- 2 x SATA3 6.0 Gb/s Connectors, support RAID (RAID 0, RAID 1, Intel Rapid Storage Technology 17), NCQ, AHCI and Hot Plug
  - 1 x Ultra M.2 Socket, support type 2280 M.2 SATA3 6.0 Gb/s module and M.2 PCI Express module up to Gen3 x4 (32 Gb/s)\*
- \* Supports Intel® Optane™ Technology  
\* Supports NVMe SSD as boot disks

**Onboard Connectors**

- 2 x CPU Fan Connectors (2 x 4-pin)
- 1 x Internal Speaker Header
- 1 x Front Panel Header
- 1 x USB 2.0 Header (Supports 2 USB 2.0 ports) (Supports ESD Protection)
- 1 x Audio Header

**Drive Bays**

- 2 x 2.5" HDD or SSD

**Power Adapter**

- 120W/19V Power Adapter

**Operation Temp.**

- 0~35°C



*Please realize that there is a certain risk involved with overclocking, including adjusting the setting in the BIOS, applying Untied Overclocking Technology, or using third-party overclocking tools. Overclocking may affect your system's stability, or even cause damage to the components and devices of your system. It should be done at your own risk and expense. We are not responsible for possible damage caused by overclocking.*

## Chapter 2 Product Overview

This chapter provides diagrams showing the location of important components of the DeskMini H470 Barebone system series.

### 2.1 Front View

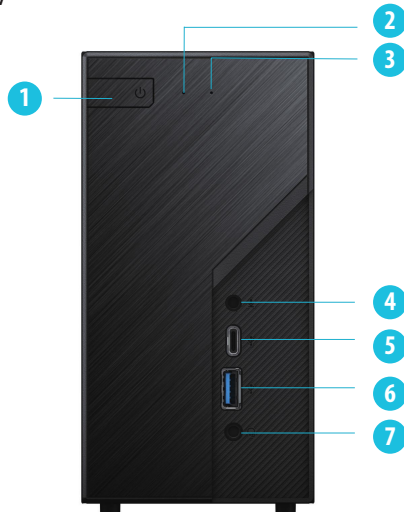

No.	Description
1	Power Button
2	Power LED
3	HDD LED
4	MIC-In
5	USB 3.2 Gen1 Type-C Port
6	USB 3.2 Gen2 Type-A Port
7	Headphone/Headset

## 2.2 Rear View

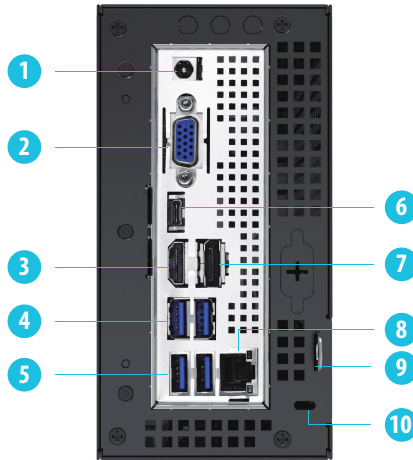

No.	Description
1	DC Jack (Supports 19V DC Power Adapters)*
2	D-Sub Port
3	HDMI Port
4	USB 3.2 Gen1 Type-A Ports
5	USB 3.2 Gen1 Type-A Ports
6	USB 3.2 Gen1 Type-C Port ( USB-C / DP Alt mode )
7	DisplayPort 1.4
8	LAN RJ-45 Port**
9	Key Lock
10	Kensington Lock

\*Specification for DC plug

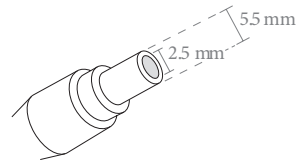

\*\* There are two LEDs on the LAN port. Please refer to the table below for the LAN port LED indications.

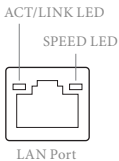

Activity / Link LED		Speed LED	
Status	Description	Status	Description
Off	No Link	Off	10Mbps connection
Blinking	Data Activity	Orange	100Mbps connection
On	Link	Green	1Gbps connection

# 1.3 Motherboard Layout

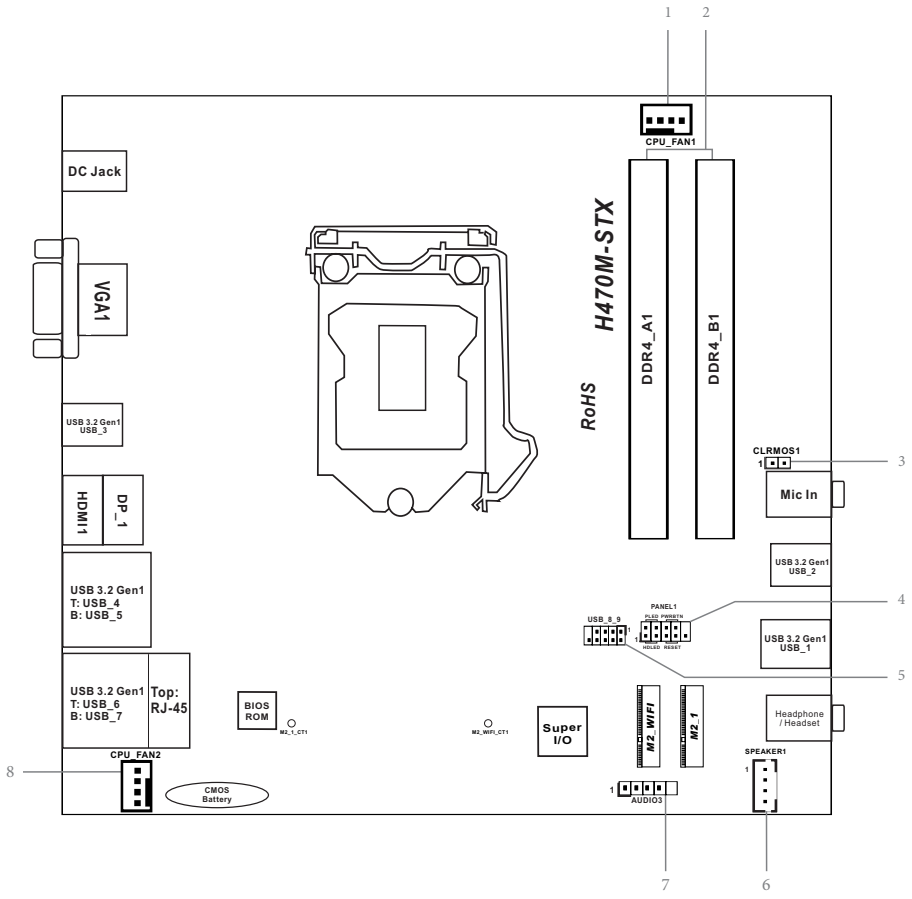

## Bottom View

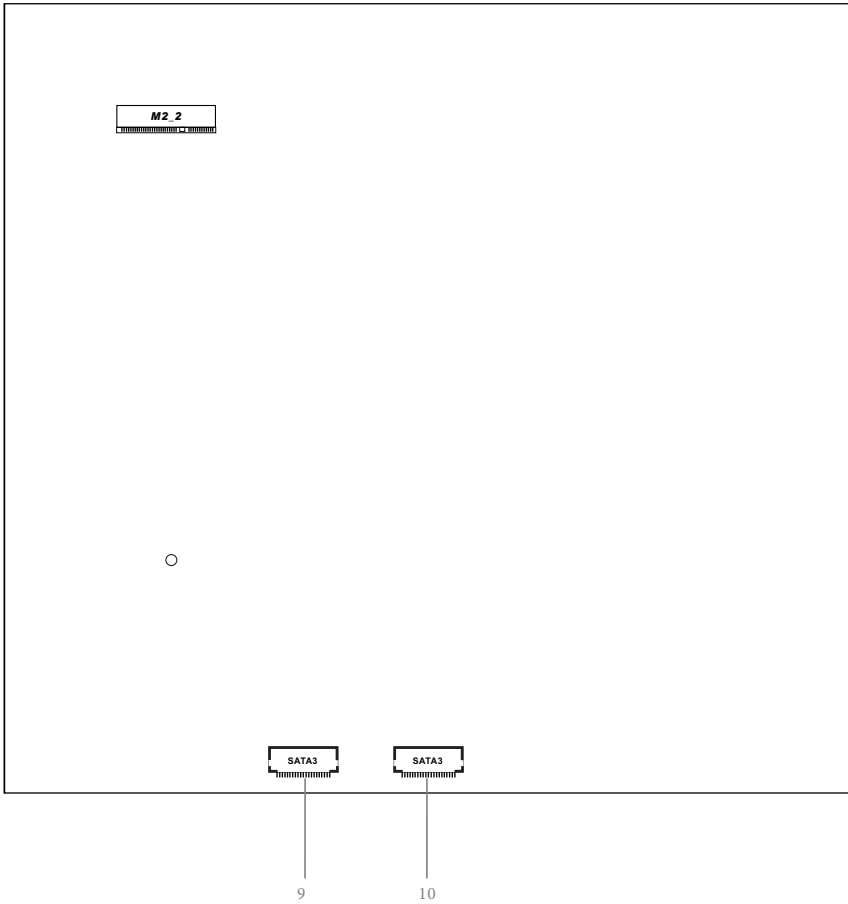



No.	Description
1	CPU Fan Connector (CPU_FAN1)
2	2 x 260-pin DDR4 SO-DIMM Slots (DDR4_A1, DDR4_B1)
3	Clear CMOS Jumper (CLRMOS1)
4	System Panel Header (PANEL1)
5	USB 2.0 Header (USB_8_9)
6	MONO Speaker Header (SPEAKER1)
7	Audio Header (AUDIO3)
8	CPU Fan Connector (CPU_FAN2)
9	SATA3 Connector (SATA2)
10	SATA3 Connector (SATA1)

## Jumpers Setup

The illustration shows how jumpers are setup. When the jumper cap is placed on the pins, the jumper is “Short”. If no jumper cap is placed on the pins, the jumper is “Open”.

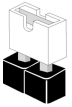

Short



Open

Clear CMOS Jumper  
(CLRCMOS1)  
(see p.6, No. 3)



2-pin Jumper

Short: Clear CMOS  
Open: Default

CLRCMOS1 allows you to clear the data in CMOS. The data in CMOS includes system setup information such as system password, date, time, and system setup parameters. To clear and reset the system parameters to default setup, please turn off the computer and unplug the power cord, then use a jumper cap to short the pins on CLRCMOS1 for 3 seconds. Please remember to remove the jumper cap after clearing the CMOS. If you need to clear the CMOS when you just finish updating the BIOS, you must boot up the system first, and then shut it down before you do the clear-CMOS action.

## Onboard Headers and Connectors



Onboard headers and connectors are NOT jumpers. Do NOT place jumper caps over these headers and connectors. Placing jumper caps over the headers and connectors will cause permanent damage to the motherboard.

System Panel Header  
(9-pin PANEL1)  
(see p.6, No. 4)

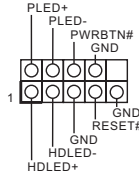

Connect the power button, reset button and system status indicator on the chassis to this header according to the pin assignments below. Note the positive and negative pins before connecting the cables.



**PWRBTN (Power Button):**

Connect to the power button on the chassis front panel. You may configure the way to turn off your system using the power button.

**RESET (Reset Button):**

Connect to the reset button on the chassis front panel. Press the reset button to restart the computer if the computer freezes and fails to perform a normal restart.

**PLED (System Power LED):**

Connect to the power status indicator on the chassis front panel. The LED is on when the system is operating. The LED keeps blinking when the system is in S1/S3 sleep state. The LED is off when the system is in S4 sleep state or powered off (S5).

**HDLED (Hard Drive Activity LED):**

Connect to the hard drive activity LED on the chassis front panel. The LED is on when the hard drive is reading or writing data.

The front panel design may differ by chassis. A front panel module mainly consists of power button, reset button, power LED, hard drive activity LED, speaker and etc. When connecting your chassis front panel module to this header, make sure the wire assignments and the pin assignments are matched correctly.

**MONO Speaker Header**  
 (4-pin SPEAKER1)  
 (see p.6, No. 6)

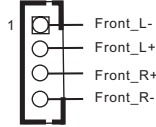

Please connect the chassis speaker to this header.

**Serial ATA3 Connectors**  
 (see p.7, No. 9 and 10)



These two SATA3 connectors support SATA data cables for internal storage devices with up to 6.0 Gb/s data transfer rate.  
 \*The SATA3 connectors support 2.5-inch hard drive (+5V) and do not support 3.5-inch hard drive (+12V)

PIN	Signal Name	PIN	Signal Name
1	GND	11	N/A
2	LVDS_TX+	12	5V
3	LVDS_TX-	13	5V
4	GND	14	5V
5	GND	15	5V
6	LVDS_RX-	16	5V
7	LVDS_RX+	17	N/A
8	GND	18	GND
9	GND	19	GND
10	GND	20	GND

**USB 2.0 Header**  
 (9-pin USB\_8\_9)  
 (see p.6, No. 5)

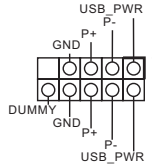

There is one header on this motherboard. This USB 2.0 header can support two ports.

**CPU Fan Connectors**  
 (4-pin CPU\_FAN1)  
 (see p.6, No. 1)

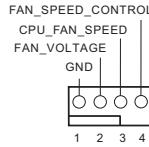

This motherboard provides two 4-Pin CPU fan (Quiet Fan) connectors. If you plan to connect a 3-Pin CPU fan, please connect it to Pin 1-3.

(4-pin CPU\_FAN2)  
 (see p.6, No. 8)

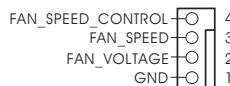

---

Audio Header  
(5-pin AUDIO3)  
(see p.6, No. 7)

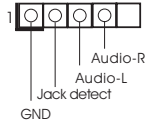

This Audio header allows you to connect the audio cable for headphones.

## Chapter 3 Hardware Installation

### 3.1 Begin Installation

1. Unscrew the four screws of the back panel.

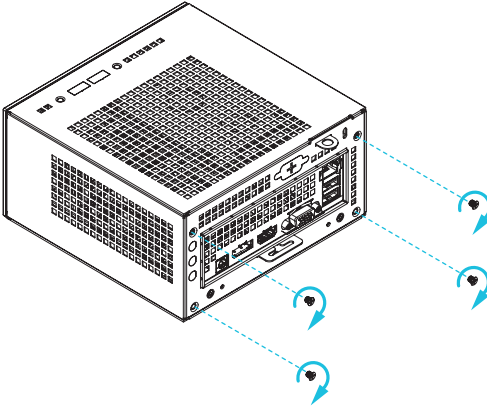

2. Pull out the motherboard tray while holding the handle.

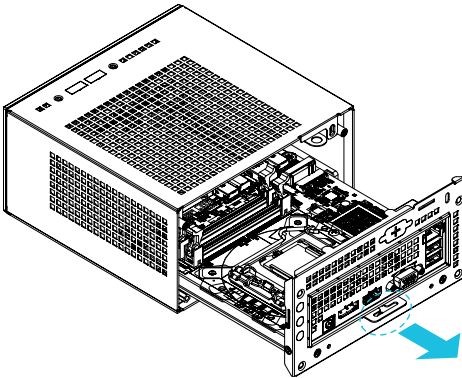

## 3.2 Installing the CPU



1. Before you insert the 1200-Pin CPU into the socket, please check if the **PnP cap** is on the socket, if the CPU surface is unclean, or if there are any **bent pins** in the socket. Do not force to insert the CPU into the socket if above situation is found. Otherwise, the CPU will be seriously damaged.
2. Unplug all power cables before installing the CPU.

1

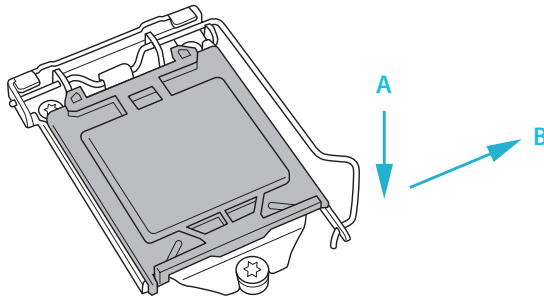

2

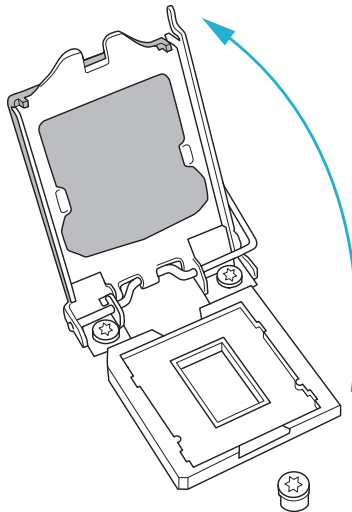

3

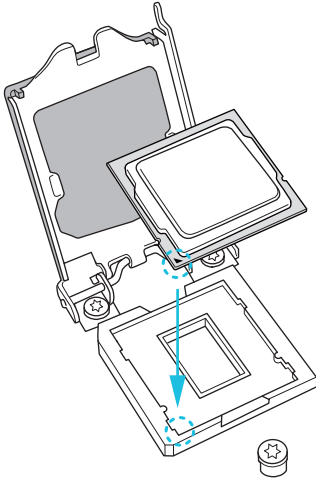

4

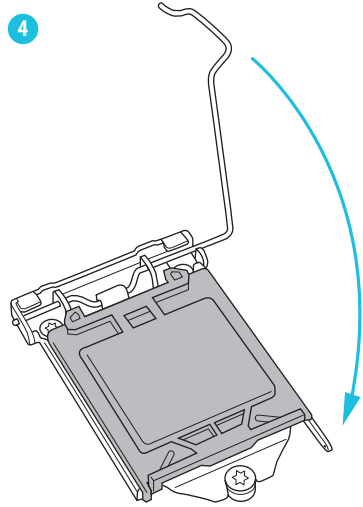

5

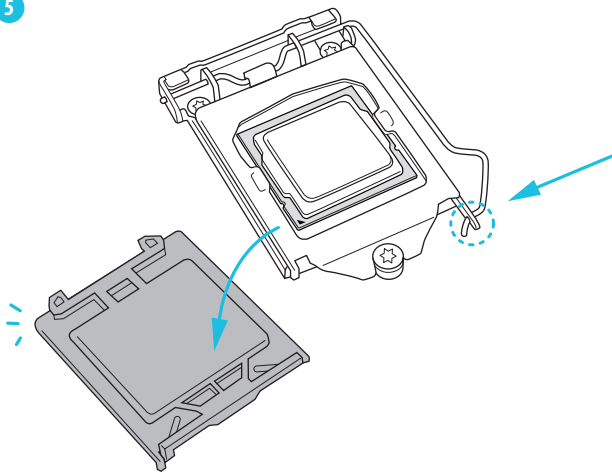



### 3.3 Installing the CPU Fan and Heatsink



*DeskMini H470 series supports both Intel CPU Box Fan (65W) and third-party CPU fan cooler. Please note that the DeskMini H470 series chassis has 52mm height limitation for the CPU fan cooler.*

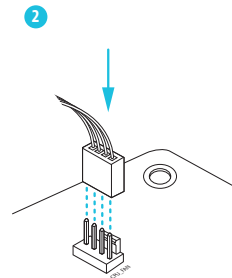
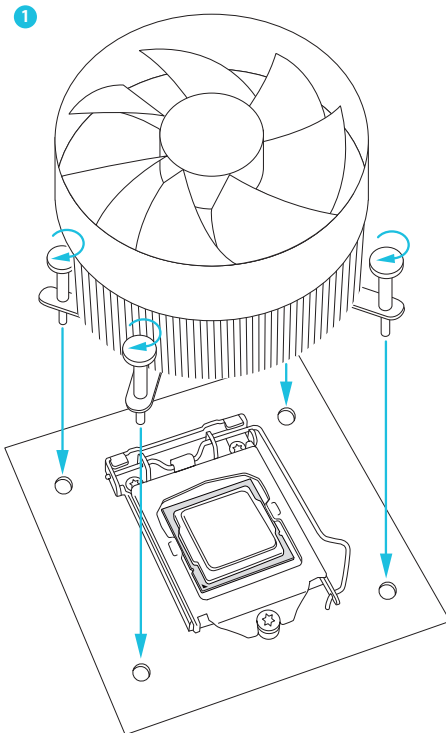
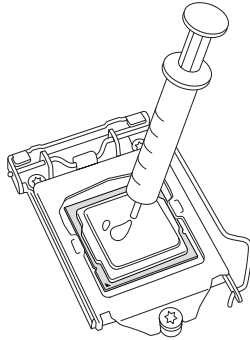

### 3.4 Installing Memory Modules (SO-DIMM)

This motherboard provides two 260-pin DDR4 (Double Data Rate 4) SO-DIMM slots.



1. DeskMini H470 series requires DDR4 SO-DIMM.
2. For dual channel configuration, you always need to install identical (the same brand, speed, size and chip-type) DDR4 SO-DIMM pairs.



1. It is not allowed to install a DDR, DDR2 or DDR3 memory module into a DDR4 slot; otherwise, this motherboard and SO-DIMM may be damaged.
2. The SO-DIMM only fits in one correct orientation. It will cause permanent damage to the motherboard and the SO-DIMM if you force the SO-DIMM into the slot at incorrect orientation.

1

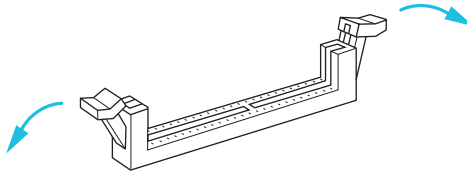

2

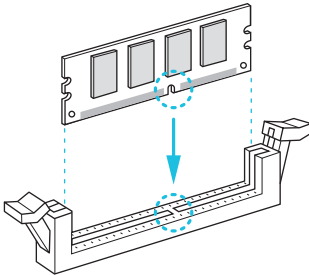

3

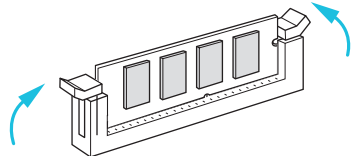

## 3.5 Installing the WiFi Module

1. Insert the WiFi Module Card into the M.2 Slot for WiFi + BT Module.

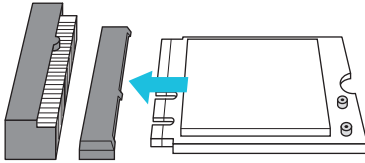

2. Tighten the screw to secure the WiFi Module Card to the motherboard.

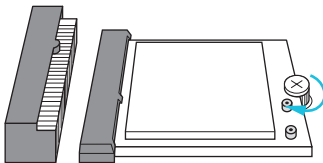

3. Attach the SMA Wi-Fi Antenna Cables to the WiFi Module.

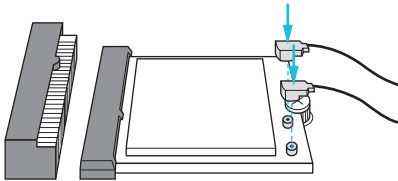

### 3.6 Installing the M.2 SSD (Type 2280)

1. Locate the M.2 slot on the motherboard.

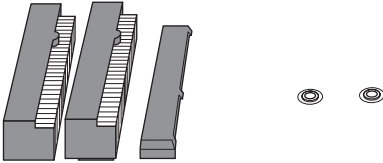

2. Carefully insert the M.2 SSD into the slot.

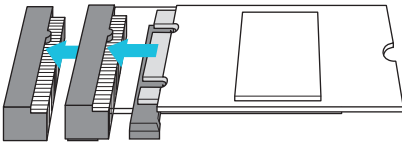

3. Tighten the screw to secure the M.2 SSD to the motherboard.

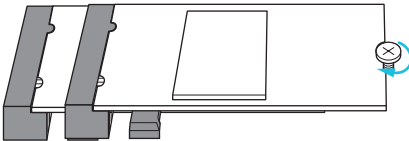

## 3.7 Installing the 2.5-inch HDD/SSD

1. Place another HDD/SSD on the tray B shown in Step 1. Then turn the motherboard tray upside down and secure the HDD/SSD with the four screws.  
\*Removing the motherboard before installing the second HDD/SSD.

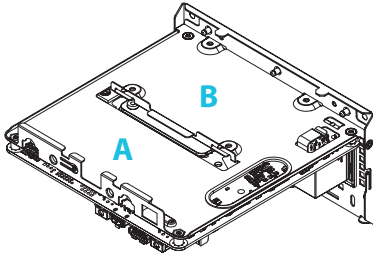

2. Connect the SATA Data and Power Cable to the HDD/SSD.

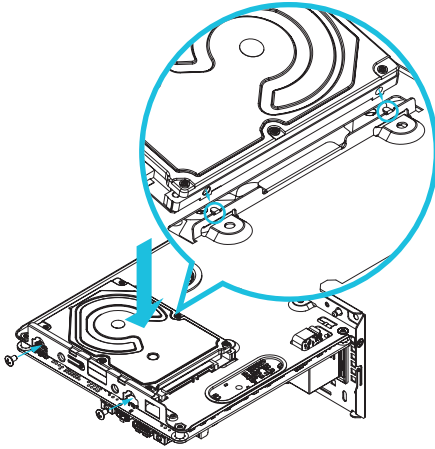

3. Connect the other end of the SATA Cables to the SATA Connectors on the motherboard.

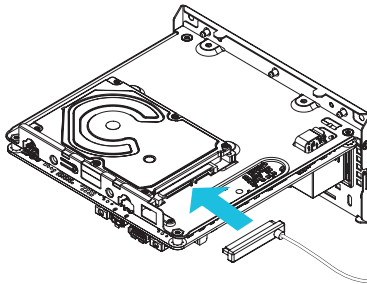

- Place another HDD/SSD on the tray B shown in Step 1.  
Then turn the motherboard tray upside down and secure the HDD/SSD with the four screws.

\*Removing the motherboard before installing the second HDD/SSD.

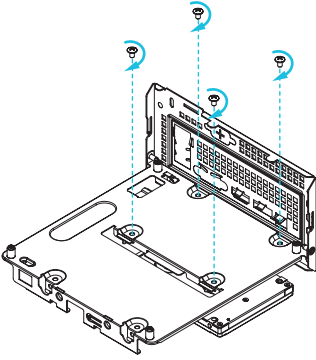

- Connect the SATA Data and Power Cable to the HDD/SSD.

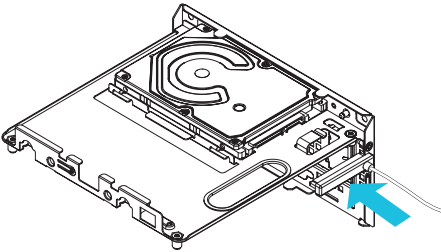

- Connect the other end of the SATA Cables to the SATA Connectors on the motherboard.

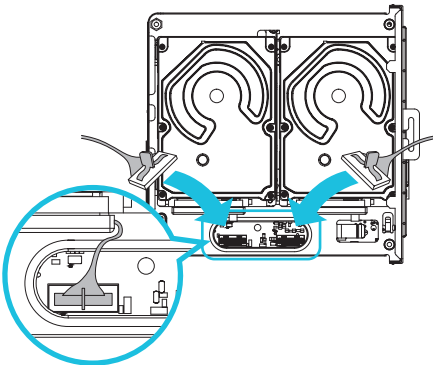

## 3.8 Complete

1. Connect the power button cable to the System Panel Header on the motherboard.

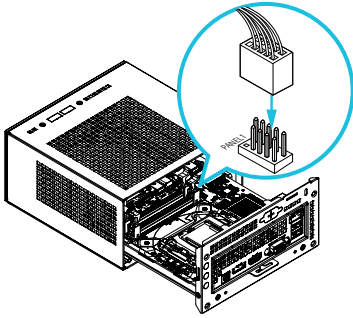

2. Align the motherboard tray with the two sliding tracks on the chassis while sliding it back to the chassis.

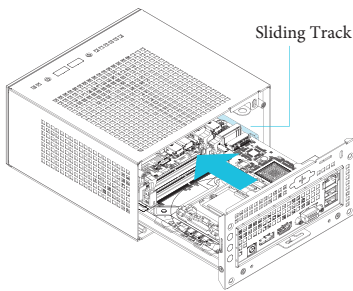

3. Then refasten the four screws that you removed earlier.

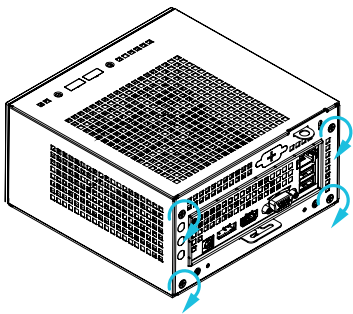

### 3.9 Installing the VESA Bracket (Optional)

1. Secure the VESA Bracket to the right side panel of the DeskMini H470 series by using the four screws.

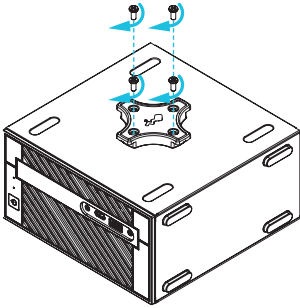

2. Attach the other VESA Bracket to the rear of a compatible display using the four screws.  
\*Choose mounting holes depending on the mounting hole pattern of your LCD screen (75 mm × 75 mm or 100 mm × 100 mm).

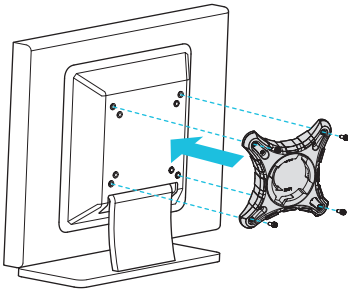

3. Mount the DeskMini H470 series by turning it counterclockwise.

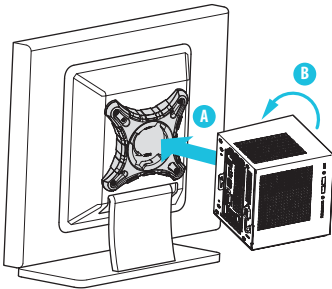



4. Complete.

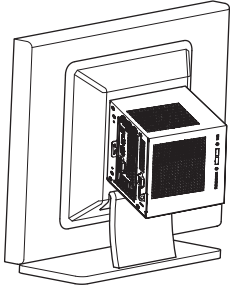

### 3.10 Installing the WiFi Antennas (Optional)

1. Insert the Wi-Fi Antenna Connectors to the antenna ports on the rear panel of the DeskMini H470 series

\*Please make sure to align the flat surface of Wi-Fi Antenna Connectors with the flat side of holes when inserting the connectors.

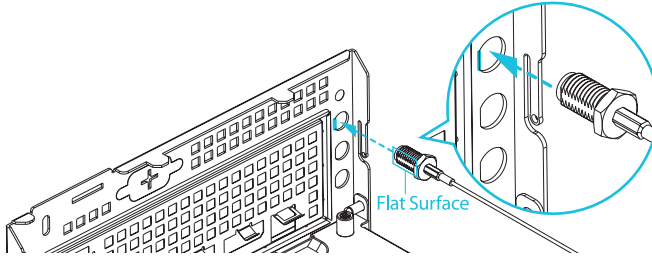

2. Fasten the screw nuts to secure the antenna connectors.

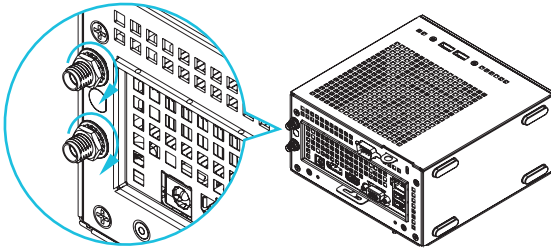

3. Connect the two WiFi 2.4/5 GHz Antennas to the antenna connectors. Turn the antenna clockwise until it is securely connected.

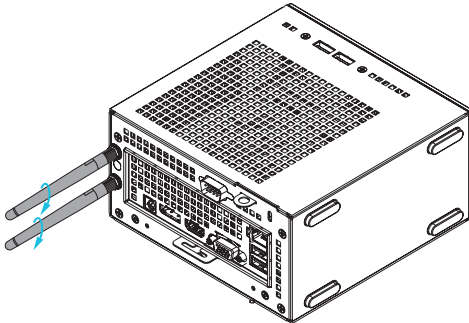

4. Set the WiFi 2.4/5 GHz Antenna at 90-degree angle.

\*You may need to adjust the direction of the antenna for a stronger signal.

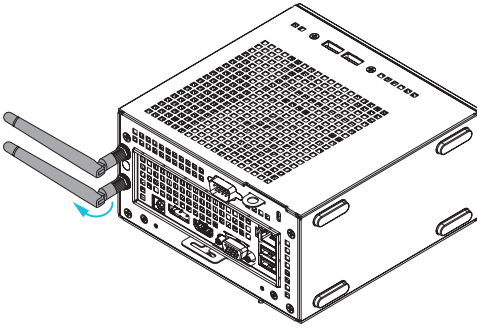

## Chapter 4 Software and Utilities Operation

### 4.1 Installing Drivers

The Support CD that comes with the motherboard contains necessary drivers and useful utilities that enhance the motherboard's features.

#### Running The Support CD

To begin using the support CD, insert the CD into your CD-ROM drive. The CD automatically displays the Main Menu if "AUTORUN" is enabled in your computer. If the Main Menu does not appear automatically, locate and double click on the file "ASRSETUP.EXE" in the Support CD to display the menu.

#### Drivers Menu

The drivers compatible to your system will be auto-detected and listed on the support CD driver page. Please click **Install All** or follow the order from top to bottom to install those required drivers. Therefore, the drivers you install can work properly.

#### Utilities Menu

The Utilities Menu shows the application software that the motherboard supports. Click on a specific item then follow the installation wizard to install it.

# Chapter 5 UEFI SETUP UTILITY

## 5.1 Introduction

This section explains how to use the UEFI SETUP UTILITY to configure your system. You may run the UEFI SETUP UTILITY by pressing <F2> or <Del> right after you power on the computer, otherwise, the Power-On-Self-Test (POST) will continue with its test routines. If you wish to enter the UEFI SETUP UTILITY after POST, restart the system by pressing <Ctl> + <Alt> + <Delete>, or by pressing the reset button on the system chassis. You may also restart by turning the system off and then back on.



*Because the UEFI software is constantly being updated, the following UEFI setup screens and descriptions are for reference purpose only, and they may not exactly match what you see on your screen.*

## 5.2 EZ Mode

The EZ Mode screen appears when you enter the BIOS setup program by default. EZ mode is a dashboard which contains multiple readings of the system's current status. You can check the most crucial information of your system, such as CPU speed, DRAM frequency, SATA information, fan speed, etc.

Press <F6> or click the "Advanced Mode" button at the upper right corner of the screen to switch to "Advanced Mode" for more options.

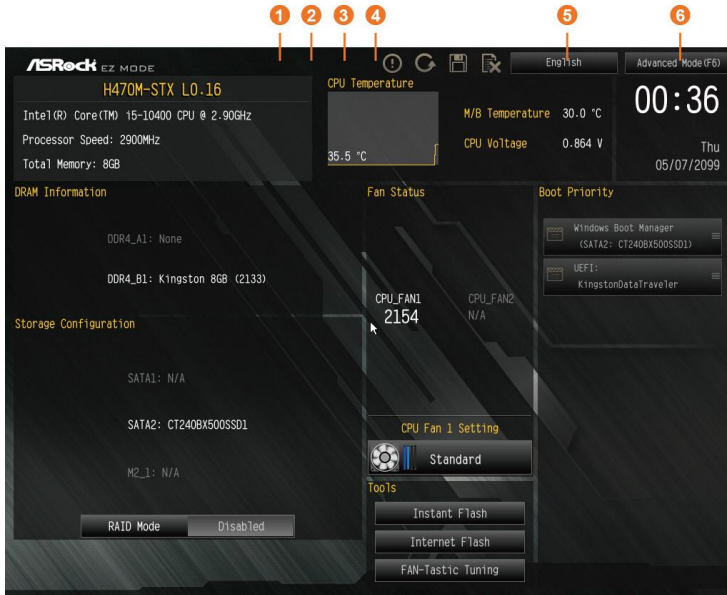

No.	Function
1	Help
2	Load UEFI Defaults
3	Save Changes and Exit
4	Discard Changes
5	Change Language
6	Switch to Advanced Mode

## 5.3 Advanced Mode

The Advanced Mode provides more options to configure the BIOS settings. Refer to the following sections for the detailed configurations.

To access the EZ Mode, press <F6> or click the "EZ Mode" button at the upper right corner of the screen.

### 5.3.1 UEFI Menu Bar

The top of the screen has a menu bar with the following selections:

<b>Main</b>	For setting system time/date information
<b>OC Tweaker</b>	For overclocking configurations
<b>Advanced</b>	For advanced system configurations
<b>Tool</b>	Useful tools
<b>H/W Monitor</b>	Displays current hardware status
<b>Security</b>	For security settings
<b>Boot</b>	For configuring boot settings and boot priority
<b>Exit</b>	Exit the current screen or the UEFI Setup Utility

### 5.3.2 Navigation Keys

Use <←> key or <→> key to choose among the selections on the menu bar, and use <↑> key or <↓> key to move the cursor up or down to select items, then press <Enter> to get into the sub screen. You can also use the mouse to click your required item.

Please check the following table for the descriptions of each navigation key.

Navigation Key(s)	Description
+ / -	To change option for the selected items
<Tab>	Switch to next function
<PGUP>	Go to the previous page
<PGDN>	Go to the next page
<HOME>	Go to the top of the screen
<END>	Go to the bottom of the screen
<F1>	To display the General Help Screen
<F5>	Add / Remove Favorite
<F7>	Discard changes and exit the SETUP UTILITY
<F9>	Load optimal default values for all the settings
<F10>	Save changes and exit the SETUP UTILITY
<F12>	Print screen
<ESC>	Jump to the Exit Screen or exit the current screen



## 5.4 Main Screen

When you enter the UEFI SETUP UTILITY, the Main screen will appear and display the system overview.



*The availability and location of BIOS settings can be different for different models and BIOS versions.*

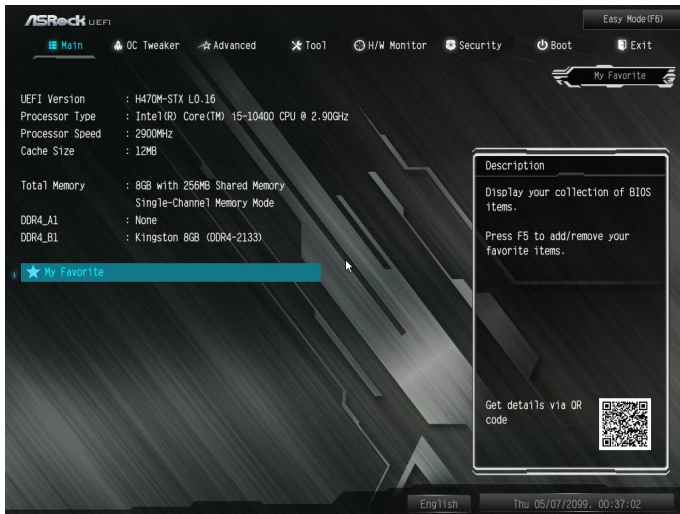

### My Favorite

Display your collection of BIOS items. Press F5 to add/remove your favorite items.

## 5.5 OC Tweaker Screen

In the OC Tweaker screen, you can set up overclocking features.



*Because the UEFI software is constantly being updated, the following UEFI setup screens and descriptions are for reference purpose only, and they may not exactly match what you see on your screen.*

### Base Frequency Boost

Via ASRock BFB (Boost Frequency Boost) Technology, users may install their non K series CPUs to ASRock's 400 series motherboards (even non Z models) and enjoy the base frequency boost with the hidden power of processors immediately.

### CPU Configuration

#### AVX Ratio Offset

AVX Ratio Offset specifies a negative offset from the CPU Ratio for AVX workloads. AVX is a more stressful workload that lower the AVX ratio to ensure maximum possible ratio for SSE workloads.

#### BCLK Spread Spectrum

Enable BCLK Spread Spectrum to reduce electromagnetic interference for passing EMI tests. Disable to achieve higher clock speeds when overclocking.

## BCLK Aware Adaptive Voltage

BCLK Aware Adaptive Voltage enable/disable. When enabled, pcode will be aware of the BCLK frequency when calculating the CPU V/F curves. This is ideal for BCLK OC to avoid high voltage overrides.

## Boot Performance Mode

Select the performance state that the BIOS will set before OS handoff.

## FCLK Frequency

Configure the FCLK Frequency.

## Ring to Core Ratio Offset

Disable Ring to Core Ratio Offset so the ring and core can run at the same frequency.

## Intel SpeedStep Technology

Intel SpeedStep technology allows processors to switch between multiple frequencies and voltage points for better power saving and heat dissipation.

## Intel Turbo Boost Technology

Intel Turbo Boost Technology enables the processor to run above its base operating frequency when the operating system requests the highest performance state.

## Intel Speed Shift Technology

Enable/Disable Intel Speed Shift Technology support. Enabling will expose the CPPC v2 interface to allow for hardware controlled P-states.

## Intel Thermal Velocity Boost Voltage Optimizations

This service controls thermal based voltage optimizations for processors that implement the Intel Thermal Velocity Boost (TVB) feature.

## Dual Tau Boost

Enable Dual Tau Boost feature. This is only applicable for CMLS 35W/65W/125W skus. This item is only supported with processors with Config TDP support.

## Long Duration Power Limit

Configure Package Power Limit 1 in watts. When the limit is exceeded, the CPU ratio will be lowered after a period of time. A lower limit can protect the CPU and save power, while a higher limit may improve performance.

## Long Duration Maintained

Configure the period of time until the CPU ratio is lowered when the Long Duration Power Limit is exceeded.

## Short Duration Power Limit

Configure Package Power Limit 2 in watts. When the limit is exceeded, the CPU ratio will be lowered immediately. A lower limit can protect the CPU and save power, while a higher limit may improve performance.

## CPU Core Current Limit

Configure the current limit of the CPU core. A lower limit can protect the CPU and save power, while a higher limit may improve performance.

## GT Current Limit

Configure the current limit of the GT slice. A lower limit can protect the CPU and save power, while a higher limit may improve performance.

## DRAM Configuration

### Memory Information

Allows users to browse the serial presence detect (SPD) and Intel extreme memory profile (XMP) for DDR4 modules.

### DRAM Timing Configuration

#### Load XMP Setting

Load XMP settings to overclock the memory and perform beyond standard specifications.

#### DRAM Frequency

If [Auto] is selected, the motherboard will detect the memory module(s) inserted and assign the appropriate frequency automatically.

#### Primary Timing

##### CAS# Latency (tCL)

The time between sending a column address to the memory and the beginning of the data in response.

##### RAS# to CAS# Delay and Row Precharge (tRCDtRP)

RAS# to CAS# Delay : The number of clock cycles required between the opening of a row of memory and accessing columns within it.

Row Precharge: The number of clock cycles required between the issuing of the precharge command and opening the next row.

### **RAS# Active Time (tRAS)**

The number of clock cycles required between a bank active command and issuing the precharge command.

### **Command Rate (CR)**

The delay between when a memory chip is selected and when the first active command can be issued.

### **Secondary Timing**

#### **Write Recovery Time (tWR)**

The amount of delay that must elapse after the completion of a valid write operation, before an active bank can be precharged.

#### **Refresh Cycle Time (tRFC)**

The number of clocks from a Refresh command until the first Activate command to the same rank.

#### **RAS to RAS Delay (tRRD\_L)**

The number of clocks between two rows activated in different banks of the same rank.

#### **RAS to RAS Delay (tRRD\_S)**

The number of clocks between two rows activated in different banks of the same rank.

#### **Write to Read Delay (tWTR\_L)**

The number of clocks between the last valid write operation and the next read command to the same internal bank.

#### **Write to Read Delay (tWTR\_S)**

The number of clocks between the last valid write operation and the next read command to the same internal bank.

#### **Read to Precharge (tRTP)**

The number of clocks that are inserted between a read command to a row precharge command to the same rank.

#### **Four Activate Window (tFAW)**

The time window in which four activates are allowed the same rank.

## CAS Write Latency (tCWL)

Configure CAS Write Latency.

## Third Timing

### tREFI

Configure refresh cycles at an average periodic interval.

### tCKE

Configure the period of time the DDR4 initiates a minimum of one refresh command internally once it enters Self-Refresh mode.

## Turn Around Timing

### tRDRD\_sg

Configure between module read to read delay.

### tRDRD\_dg

Configure between module read to read delay.

### tRDRD\_dr

Configure between module read to read delay.

### tRDRD\_dd

Configure between module read to read delay.

### tRDWR\_sg

Configure between module read to write delay.

### tRDWR\_dg

Configure between module read to write delay.

### tRDWR\_dr

Configure between module read to write delay.

### tRDWR\_dd

Configure between module read to write delay.

### tWRRD\_sg

Configure between module write to read delay.

### tWRRD\_dg

Configure between module write to read delay.

### tWRRD\_dr

Configure between module write to read delay.

### tWRRD\_dd

Configure between module write to read delay.

### tWRWR\_sg

Configure between module write to write delay.

### tWRWR\_dg

Configure between module write to write delay.

### tWRWR\_dr

Configure between module write to write delay.

### tWRWR\_dd

Configure between module write to write delay.

## Round Trip Timing

### RTL Init Value

Configure round trip latency init value for round trip latency training.

### IO-L Init Value

Configure IO latency init value for IO latency training.

### RTL (CH A)

Configure round trip latency for channel A.

### RTL (CH B)

Configure round trip latency for channel B.

### IO-L (CH A)

Configure IO latency for channel A.

### IO-L (CH B)

Configure IO latency for channel B.

**IO-L Offset (CH A)**

Configure IO latency offset for channel A.

**IO-L Offset (CH B)**

Configure IO latency offset for channel B.

**RFR Delay (CH A)**

Configure RFR Delay for Channel A.

**RFR Delay (CH B)**

Configure RFR Delay for Channel B.

**ODT Setting****ODT WR (A1)**

Configure the memory on die termination resistors' WR for channel A.

**ODT WR (B1)**

Configure the memory on die termination resistors' WR for channel B.

**ODT NOM (A1)**

Use this to change ODT (CH A) Auto/Manual settings. The default is [Auto].

**ODT NOM (B1)**

Use this to change ODT (CH B) Auto/Manual settings. The default is [Auto].

**ODT PARK (A1)**

Configure the memory on die termination resistors' PARK for channel A.

**ODT PARK (B1)**

Configure the memory on die termination resistors' PARK for channel B.

**Advanced Setting****ASRock Timing Optimization**

Configure the fast path through the MRC.

**Realtime Memory Timing**

Configure the realtime memory timings.

[Enabled] The system will allow performing realtime memory timing changes after MRC\_DONE.



## Command Tristate

Configure the Command Tristate Support.

## Exit On Failure

Configure the Exit On Failure for MRC training steps.

## Reset On Training Fail

Reset system if the MRC training fails.

## MRC Fast Boot

Enable Memory Fast Boot to skip DRAM memory training for booting faster.

## Voltage Configuration

### CPU V/F Curve

Configure CPU Voltage/Frequency Curve.

### Performance Mode

Select the performance state that the BIOS will set before OS handoff.

### Adapter Select

Select the adapter.

### DRAM Voltage

Use this to configure DRAM Voltage. The default value is [Auto].

## 5.6 Advanced Screen

In this section, you may set the configurations for the following items: CPU Configuration, Chipset Configuration, Storage Configuration, ACPI Configuration, USB Configuration and Trusted Computing.



*Setting wrong values in this section may cause the system to malfunction.*

### UEFI Configuration

#### UEFI Setup Style

Select the default mode when entering the UEFI setup utility.

#### Active Page on Entry

Select the default page when entering the UEFI setup utility.

#### Full HD UEFI

When [Auto] is selected, the resolution will be set to 1920 x 1080 if the monitor supports Full HD resolution. If the monitor does not support Full HD resolution, then the resolution will be set to 1024 x 768. When [Disable] is selected, the resolution will be set to 1024 x 768 directly.

## 5.6.1 CPU Configuration



### Intel Hyper-Threading Technology

Intel Hyper-Threading Technology allows multiple threads to run on each core, so that the overall performance on threaded software is improved.

### Active Processor Cores

Select the number of cores to enable in each processor package.

### CPU C States Support

Enable CPU C States Support for power saving. It is recommended to keep C3, C6 C7 and C10 all enabled for better power saving.

### Enhanced Halt State (C1E)

Enable Enhanced Halt State (C1E) for lower power consumption.

### CPU C3 State Support

Enable C3 deep sleep state for lower power consumption.

### CPU C6 State Support

Enable C6 deep sleep state for lower power consumption.

### CPU C7 State Support

Enable C7 deep sleep state for lower power consumption.

### CPU C10 State Support

Enable C10 deep sleep state for lower power consumption.

### Package C State Support

Enable CPU, PCIe, Memory, Graphics C State Support for power saving.

### CFG Lock

This item allows you to disable or enable the CFG Lock.

### CPU Thermal Throttling

Enable CPU internal thermal control mechanisms to keep the CPU from overheating.

### Intel Virtualization Technology

Intel Virtualization Technology allows a platform to run multiple operating systems and applications in independent partitions, so that one computer system can function as multiple virtual systems.

### Hardware Prefetcher

Automatically prefetch data and code for the processor. Enable for better performance.

### Adjacent Cache Line Prefetch

Automatically prefetch the subsequent cache line while retrieving the currently requested cache line. Enable for better performance.

### Software Guard Extensions (SGX)

Intel SGX is a set of new CPU instructions that can be used by applications to set aside private regions of code and data.

## 5.6.2 Chipset Configuration

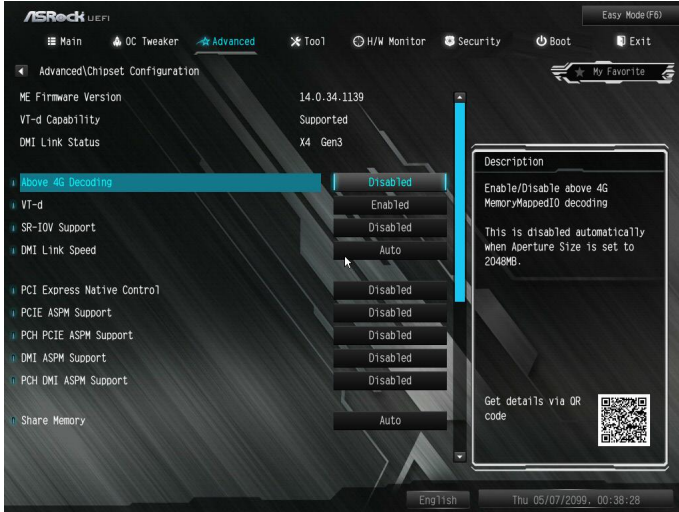

### Above 4G Decoding

Enable or disable 64bit capable Devices to be decoded in Above 4G Address Space (only if the system supports 64 bit PCI decoding).

### VT-d

Intel® Virtualization Technology for Directed I/O helps your virtual machine monitor better utilize hardware by improving application compatibility and reliability, and providing additional levels of manageability, security, isolation, and I/O performance.

### SR-IOV Support

If system has SR-IOV capable PCIe Devices, this option Enables or Disables Single Root IO Virtualization Support.

### DMI Link Speed

Configure DMI Slot Link Speed. Auto mode is optimizing for overclocking.

### PCI Express Native Control

Select Enable for enhanced PCI Express power saving in OS.

### PCIE ASPM Support

This option enables/disables the ASPM support for all CPU downstream devices.

### PCH PCIE ASPM Support

This option enables/disables the ASPM support for all PCH PCIE devices.

### DMI ASPM Support

This option enables/disables the control of ASPM on CPU side of the DMI Link.

### PCH DMI ASPM Support

This option enables/disables the ASPM support for all PCH DMI devices.

### Share Memory

Configure the size of memory that is allocated to the integrated graphics processor when the system boots up.

### Inte(R) Ethernet Connection I219-V

Enable or disable the onboard network interface controller (Intel® I219V).

### Onboard HD Audio

Enable/disable onboard HD audio. Set to Auto to enable onboard HD audio and automatically disable it when a sound card is installed.

### Internal Speaker

Enable/disable the internal speaker.

### Onboard HDMI HD Audio

Enable audio for the onboard digital outputs.

### Onboard WAN Device

Use this item to enable or disable the onboard WAN device.

### WAN Radio

Enable/disable the WiFi module's connectivity.

### Bluetooth

Enable/disable the Bluetooth connectivity.

### Deep Sleep

Configure deep sleep mode for power saving when the computer is shut down.

---

## Restore on AC/Power Loss

Select the power state after a power failure. If [Power Off] is selected, the power will remain off when the power recovers. If [Power On] is selected, the system will start to boot up when the power recovers.

## 5.6.3 Storage Configuration



### SATA Controller(s)

Enable/disable the SATA controllers.

### SATA Mode Selection

AHCI: Supports new features that improve performance.

RAID: Combine multiple disk drives into a logical unit.

### SATA Aggressive Link Power Management

SATA Aggressive Link Power Management allows SATA devices to enter a low power state during periods of inactivity to save power. It is only supported by AHCI mode.

### Hard Disk S.M.A.R.T.

S.M.A.R.T stands for Self-Monitoring, Analysis, and Reporting Technology. It is a monitoring system for computer hard disk drives to detect and report on various indicators of reliability.



## 5.6.4 ACPI Configuration



### Suspend to RAM

Select disable for ACPI suspend type S1. It is recommended to select auto for ACPI S3 power saving.

### I219 LAN Power On

Allow the system to be waked up by the Onboard Intel LAN.

### RTC Alarm Power On

Allow the system to be waked up by the real time clock alarm. Set it to By OS to let it be handled by your operating system.

### USB Keyboard/Remote Power On

Allow the system to be waked up by an USB keyboard or remote controller.

### USB Mouse Power On

Allow the system to be waked up by an USB mouse.

## 5.6.5 USB Configuration



### Legacy USB Support

Enable or disable Legacy OS Support for USB 2.0 devices. If you encounter USB compatibility issues it is recommended to disable legacy USB support. Select UEFI Setup Only to support USB devices under the UEFI setup and Windows/Linux operating systems only.

### XHCI Hand-off

This is a workaround for OSes without XHCI hand-off support. The XHCI ownership change should be claimed by XHCI driver.

## 5.6.6 Trusted Computing



*NOTE: Options vary depending on the version of your connected TPM module.*

### Security Device Support

Use this item to enable or disable BIOS support for security device. O.S. will not show Security Device. TCG EFI protocol and INT1A interface will not be available.

### SHA-1 PCR Bank

Use this item to enable or disable SHA-1 PCR Bank.

### SHA256 PCR Bank

Use this item to enable or disable SHA256 PCR Bank.

### Pending Operation

Schedule an Operation for the Security Device.

**NOTE:** Your computer will reboot during restart in order to change State of the Device.

### Platform Hierarchy

Use this item to enable or disable Platform Hierarchy.

### Storage Hierarchy

Use this item to enable or disable Storage Hierarchy.

### Endorsement Hierarchy

Use this item to enable or disable Endorsement Hierarchy.

## TPM2.0 UEFI Spec Version

Use this item to select the TCG2 spec. version supported.

The optional settings: [TCG\_1\_2]; [TCG\_2].

[TCG\_1\_2]: compatible mode for Win8/Win10.

[TCG\_2]: for TCG2 newer spec. compatible mode for Win10

## Physical Presence Spec version

Select this item to tell OS to support PPI spec version 1.2 or 1.3. Please note that some HCK tests might not support version 1.3.

## Device Select

Use this item to select the TPM device to be supported. TPM 1.2 will restrict support to TPM 1.2 devices. TPM 2.0 will restrict support to TPM 2.0 devices. Auto will support both with the default set to TPM 2.0 devices. If TPM 2.0 devices are not found, TPM 1.2 devices will be enumerated.

## 5.7 Tools

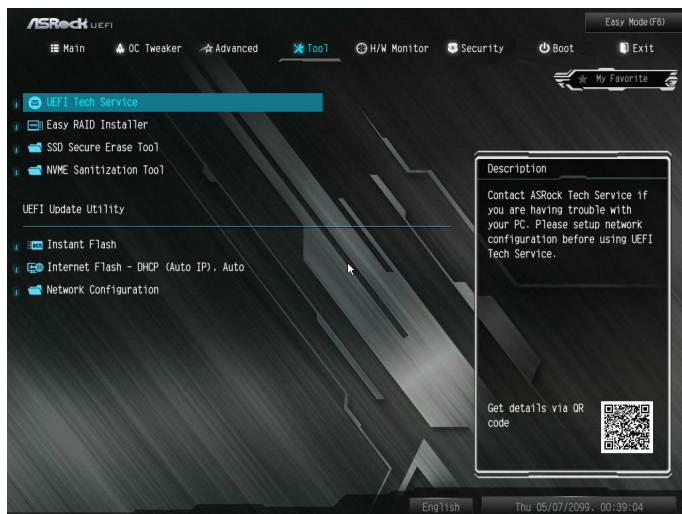

### UEFI Tech Service

Contact ASRock Tech Service if you are having trouble with your PC. Please setup network configuration before using UEFI Tech Service.

### Easy RAID Installer

Easy RAID Installer helps you to copy the RAID driver from the support CD to your USB storage device. After copying the drivers please change the SATA mode to RAID, then you can start installing the operating system in RAID mode.

### SSD Secure Erase Tool

All the SSD's listed that supports Secure Erase function.

### NVME Sanitization Tool

After you Sanitize SSD, all user data will be permanently destroyed on the SSD and cannot be recovered.

### Instant Flash

Save UEFI files in your USB storage device and run Instant Flash to update your UEFI.

## Internet Flash - DHCP (Auto IP), Auto

ASRock Internet Flash downloads and updates the latest UEFI firmware version from our servers for you. Please setup network configuration before using Internet Flash.

\*For BIOS backup and recovery purpose, it is recommended to plug in your USB pen drive before using this function.

## Network Configuration

Use this to configure internet connection settings for Internet Flash.

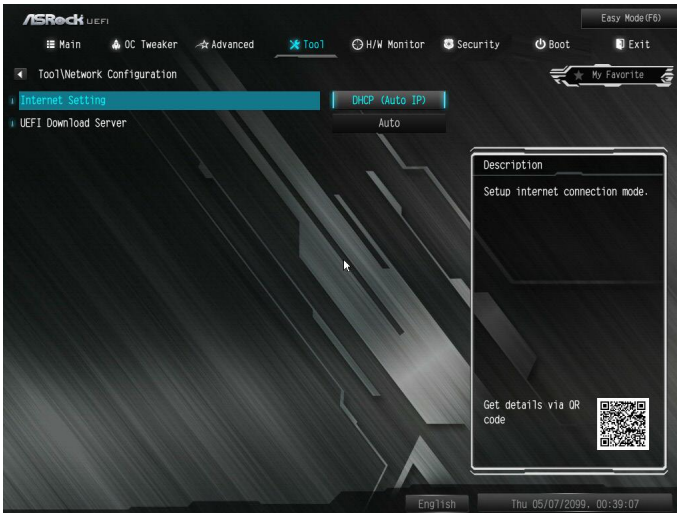

### Internet Setting

Enable or disable sound effects in the setup utility.

### UEFI Download Server

Select a server to download the UEFI firmware.

## 5.8 Hardware Health Event Monitoring Screen

This section allows you to monitor the status of the hardware on your system, including the parameters of the CPU temperature, motherboard temperature, fan speed and voltage.



### Fan Tuning

Measure Fan Min Duty Cycle.

### Fan-Tastic Tuning

Select a fan mode for CPU Fan, or choose Customize to set 5 CPU temperatures and assign a respective fan speed for each temperature.

### CPU Fan 1 Setting

Select a fan mode for CPU Fan 1, or choose Customize to set 5 CPU temperatures and assign a respective fan speed for each temperature.

### CPU Fan 2 Setting

Select a fan mode for CPU Fan 2, or choose Customize to set 5 CPU temperatures and assign a respective fan speed for each temperature.

## 5.9 Security Screen

In this section you may set or change the supervisor/user password for the system. You may also clear the user password.

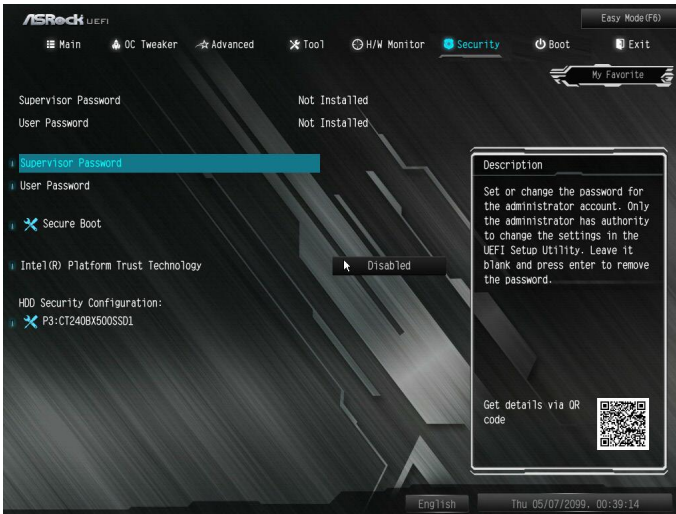

### Supervisor Password

Set or change the password for the administrator account. Only the administrator has authority to change the settings in the UEFI Setup Utility. Leave it blank and press enter to remove the password.

### User Password

Set or change the password for the user account. Users are unable to change the settings in the UEFI Setup Utility. Leave it blank and press enter to remove the password.

### Secure Boot

Use this item to enable or disable support for Secure Boot.

### Intel(R) Platform Trust Technology

Enable/disable Intel PTT in ME. Disable this option to use discrete TPM Module.



## 5.10 Boot Screen

This section displays the available devices on your system for you to configure the boot settings and the boot priority.



### Fast Boot

Fast Boot minimizes your computer's boot time. In fast mode you may not boot from an USB storage device. The VBIOS must support UEFI GOP if you are using an external graphics card. Please notice that Ultra Fast mode will boot so fast that the only way to enter this UEFI Setup Utility is to Clear CMOS or run the Restart to UEFI utility in Windows.

### Boot From Onboard LAN

Allow the system to be waked up by the onboard LAN.

### Setup Prompt Timeout

Configure the number of seconds to wait for the setup hot key.

### Bootup Num-Lock

Select whether Num Lock should be turned on or off when the system boots up.

### Boot Beep

Select whether the Boot Beep should be turned on or off when the system boots up. Please note that a buzzer is needed.

## Full Screen Logo

Enable to display the boot logo or disable to show normal POST messages.

## AddOn ROM Display

Enable AddOn ROM Display to see the AddOn ROM messages or configure the AddOn ROM if you've enabled Full Screen Logo. Disable for faster boot speed.

## Boot Failure Guard Message

If the computer fails to boot for a number of times the system automatically restores the default settings.

## CSM (Compatibility Support Module)

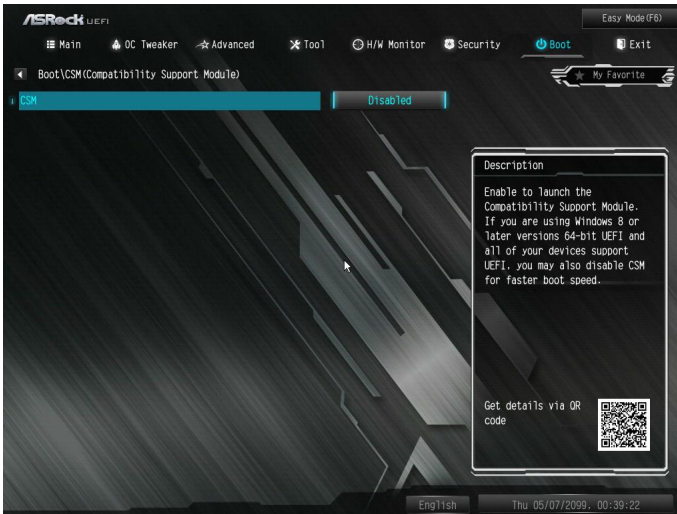

## CSM

Enable to launch the Compatibility Support Module. Please do not disable unless you're running a WHCK test.

## Launch PXE OpROM Policy

Select UEFI only to run those that support UEFI option ROM only. Select Legacy only to run those that support legacy option ROM only. Select Do not launch to not execute both legacy and UEFI option ROM.

---

## Launch Storage OpROM Policy

Select UEFI only to run those that support UEFI option ROM only. Select Legacy only to run those that support legacy option ROM only. Select Do not launch to not execute both legacy and UEFI option ROM.

## Other PCI Device ROM Priority

For PCI devices other than Network. Mass storage or Video defines which OpROM to launch.